

Knox County Code Administration & Inspection

2018 IRC Residential Stairs Information

Rev 022019

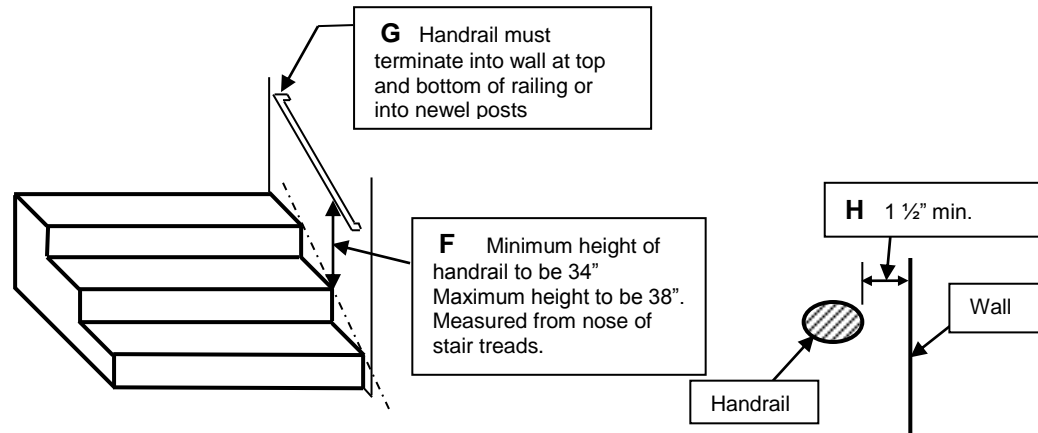

HANDRAILS

I Spindles to be spaced such that a 4" sphere will not pass through when located on side of stairs

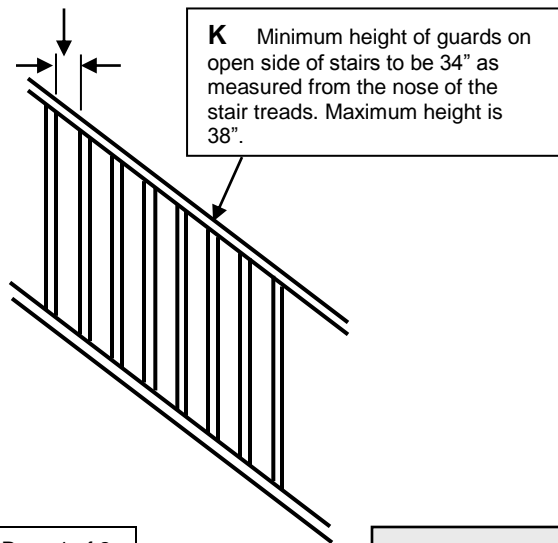

J Minimum height of guards on porches, balconies, or raised floors is 36"

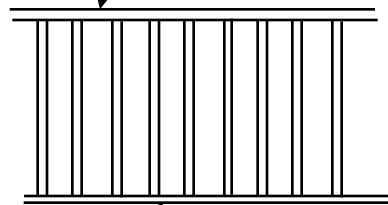

L Spindles to be spaced such that a 4" sphere will not pass through.

GUARDRAILS

2018 IRC Section R311.7.8 HANDRAILS

R311.7.8 Handrails. Handrails **F** having minimum and maximum heights of 34 inches and 38 inches respectively, measured vertically from the sloped plain adjoining the tread nosing or finished surface of ramp slope shall be provided on at least one side of each flight of stairs with four or more risers. Spiral stairways shall have the required handrail located on the outside radius. All required handrails shall be continuous the full length of the stairs. **G** Ends shall be returned or shall terminate in newel posts or safety terminals. Handrails adjacent to a wall **H** shall have a space of not less than 1½ inch between the wall and the handrail.

Exceptions:

1. Handrails shall be permitted to be interrupted by a newel post at a turn.
2. The use of a volute, turnout, starting easing or starting newel shall be allowed over the lowest tread.

R311.7.8.5 Grip size. Handrails shall have either a circular cross section with a diameter of 1 ¼ inches to 2 inches, or a noncircular cross section with a perimeter dimension of at least 4 inches but not more than 6 ¼ inches and a largest cross section dimension not exceeding 2 ¼ inches.

R 311.7.9 Illumination. All stairs shall be provided with illumination in accordance with Section R303.7 and R303.8.

2018 IRC Section R312 GUARDS

R312.1 Guards. **J** Porches, balconies, ramps or raised floor surfaces located more than 30 inches above the floor or ground below shall have guards not less than 36 inches in height. Open sides of stairs with four or more risers **K** shall have guards not less than 34 inches in height measured vertically from the nosing of the treads. Porches and decks which are enclosed with insect screening shall be equipped with guards where the walking surface is located more than 30 inches from the floor or grade below.

R312.1.3 Opening limitations. **L** required guards on open sides of stairways, raised floor areas, balconies and porches shall have intermediate rails or ornamental closures which do not allow passage of a sphere 4 inches or more in diameter.

Exceptions:

1. The triangular openings formed by the riser, tread and bottom rail of a guard at the open side of a stairway may be of such a size that a sphere 6 inches cannot pass through.
2. Openings for required guards on the sides of stair treads shall not allow a sphere 4 3/8" inches to pass through. **I**

This handout is intended to be a guide. It is by no means all-inclusive or has all code related sections listed. The IRC 2018 Residential Code with amendments was used to prepare this document. Contact the Knox County Code Administration for any additional information. (865) 215-2325.

Knox County Code Administration & Inspection

IRC Residential Stairs Information



Rev 112012

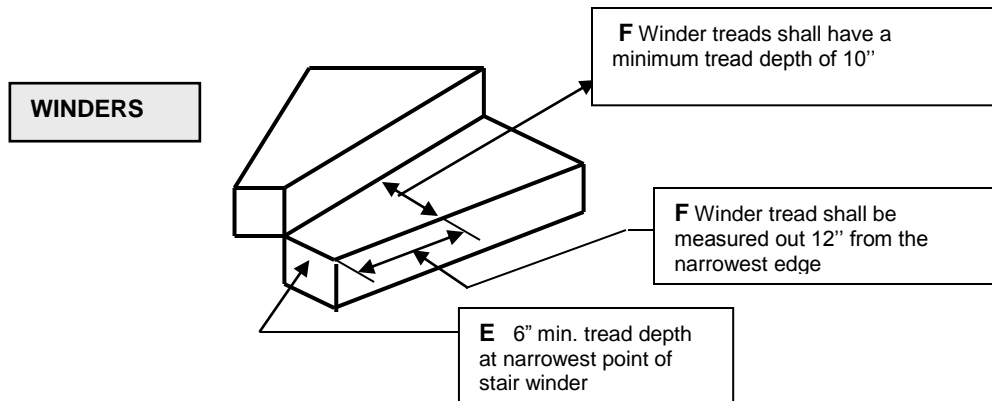
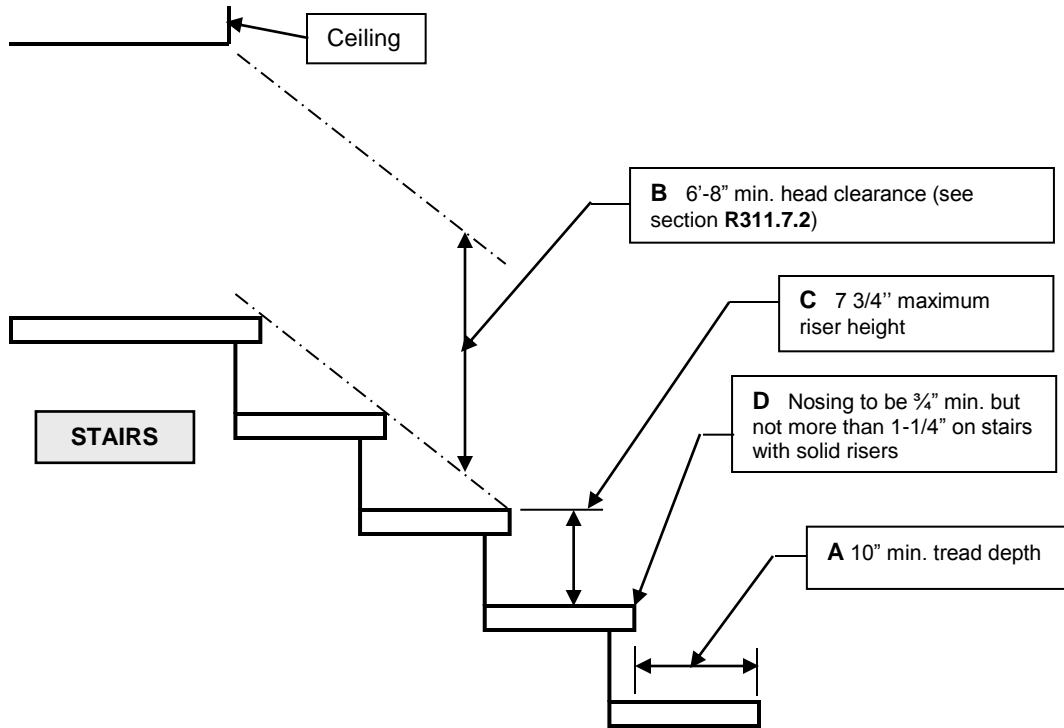

2018 IRC Section R311.7

STAIRWAYS

R311.7.5.2 Tread Depth. A The minimum tread depth shall be 10". The tread depth shall be measured horizontally between the vertical planes of the foremost projection of adjacent treads and at a right angle to the tread's leading edge. The greatest tread depth within any flight of stairs shall not exceed the smallest by more than 3/8".

R311.7.2 Headroom. B The minimum headroom in all parts of the stairway shall not be less than 6 feet 8 inches measured vertically from the sloped plane adjoining the tread nosing or from the floor surface of the landing or platform.

R311.7.5.1 Riser Height. C The maximum riser height shall be 7 3/4". The riser shall be measured vertically between leading edges of the adjacent treads. The greatest riser height within any flight of stairs shall not exceed the smallest by more than 3/8".

R311.7.5.3. Nosings. D Nosing of not less than 3/4" but not more than 1 1/4" shall be provided on treads, landings, and floors of stairways with solid risers.
Exception: Nosings are not required when the stair treads have a minimum depth of 11".

WINDERS

R311.7.5.2.1 Winder treads. E Winder treads shall have a minimum tread depth of 6" at any point.

R311.7.5.2.1 Minimum Tread Depth 12" Out From Narrow Edges. F Winder tread shall have a minimum tread depth of 10" inches at a point 12" from the side where the treads are narrower. The tread depth shall be measured horizontally between the vertical planes of the foremost projection of adjacent treads and at a right angle to the tread's leading edge. Within any flight of stairs, the largest winder tread depth at the 12" walk line shall not exceed the smallest by more than 3/8".

NOTES:

1. A door cannot swing out over steps.
2. Guardrails / Handrails shall be designed and constructed as to withstand a concentrated load of 200 lbs. applied at any point in any direction.